

SIDES	BOTTOM
4 1/2" KNOCKOUTS	3 1/2" KNOCKOUTS
5 1/2"-3/4" MOON KNOCKOUTS	2 1/2"-3/4" MOON KNOCKOUTS
2 PCS 8-32×1/2 Screws Installed	
Material:Steel-0.0625"-G60 Galvanized	

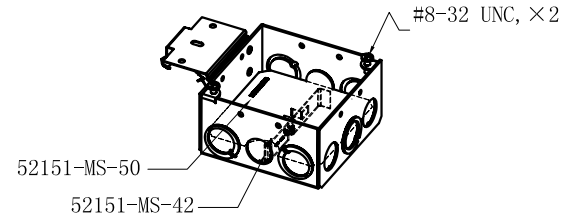

**WELDING STYLE DETAIL VIEW D**

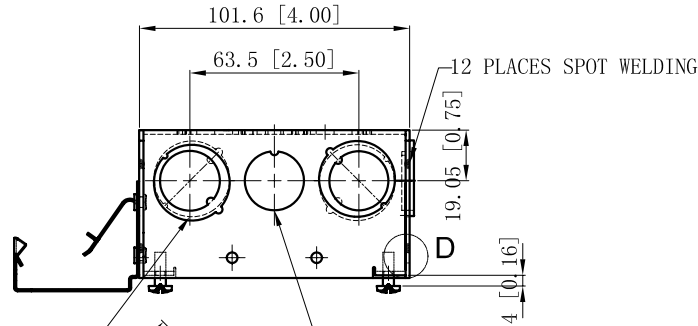

4 1/2"-3/4" MOON KNOCKOUTS  $\phi=22.5$  [ $\phi=0.89$ ]  
 $\phi=28.5$  [ $\phi=1.12$ ] MIRROR

2 1/2" KNOCKOUTS  $\phi=22.5$  [ $\phi=0.89$ ] MIRROR

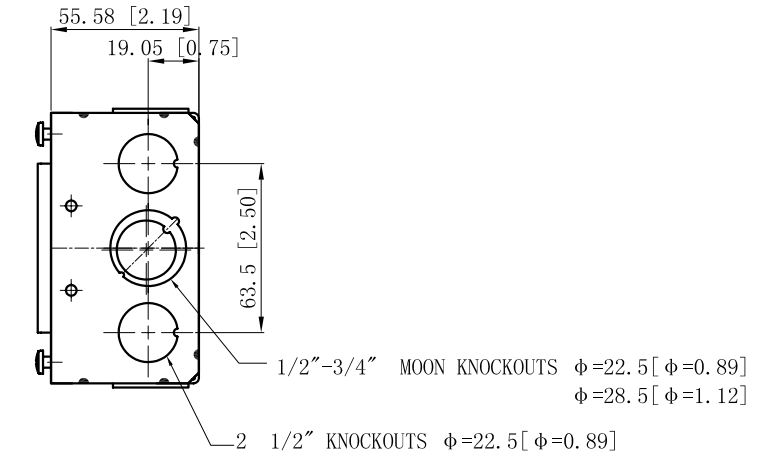
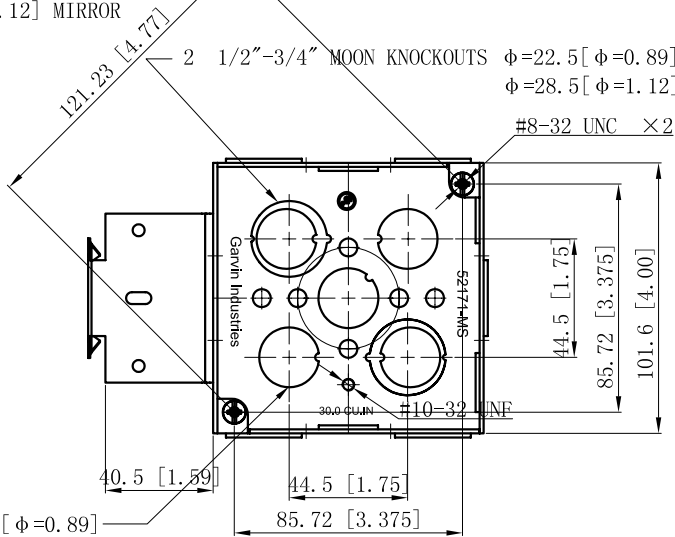
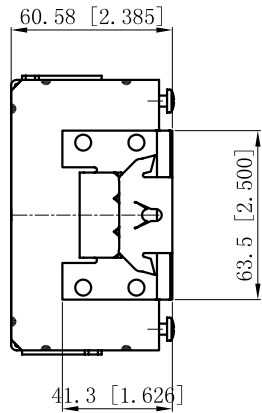

3 1/2" KNOCKOUTS  $\phi=22.5$  [ $\phi=0.89$ ]

DESCRIPTION
TRADE REFERENCE TERMS

This data sheet is for reference only .GARVIN INDUSTRIES reserves the right to make changes to the design without prior notice.

STANDARD PACKING	<h1>GARVIN INDUSTRIES</h1>		
25 PCS			
TITLE	4" SQUARE BRACKET BOXES (2-1/8" DEEP)		
SIZE	DWG NO.	REV	
A4	52171-MS	A	
DATA SHEET			