

<b>SIDES</b>	<b>BOTTOM</b>
8 3/4" KNOCKOUTS	1 Ground Hump
1 PCS 10-32×3/8 Screws Installed	
2 PCS 8-32×1/2 Screws Installed	
Material: Steel-0.0625"-G60 Galvanized	

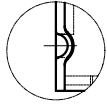

WELDING STYLE DETAIL VIEW A

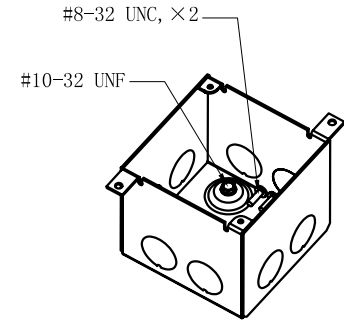
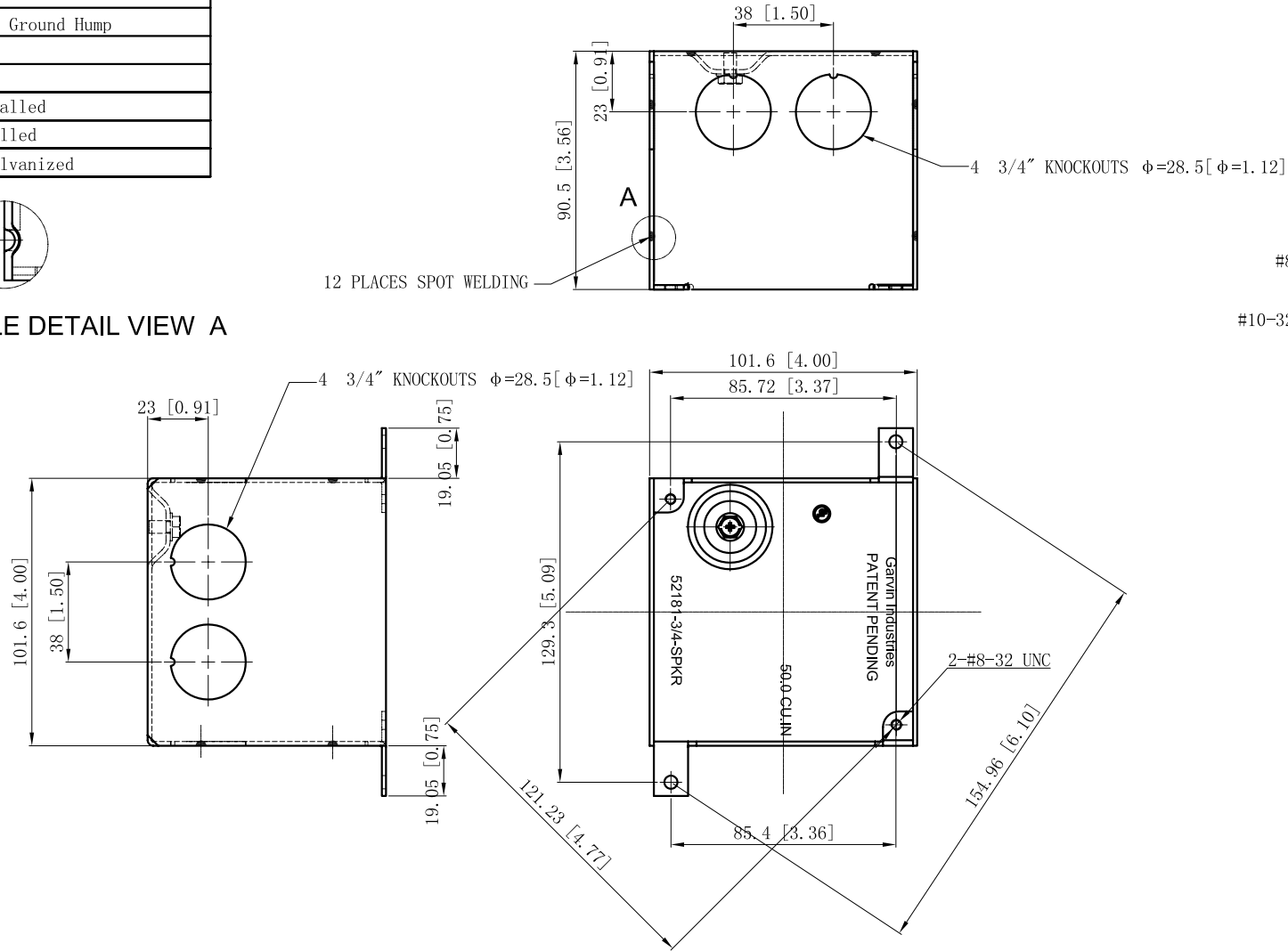

This data sheet is for reference only .GARVIN INDUSTRIES reserves the right to make changes to the design without prior notice.

DESCRIPTION
TRADE REFERENCE TERMS

STANDARD PACKING
25 PCS

<b>GARVIN INDUSTRIES</b>		
TITLE 4" SQUARE BOXES 3-1/2" DEEP		
SIZE A4	DWG NO. 52181-3/4-SPKR	REV
DATA SHEET		