

SIDES	BOTTOM
8 1" KNOCKOUTS	3 1/2" KNOCKOUTS
	2 3/4" KNOCKOUTS
	1 GROUD HUMP
2 PCS #8-32×1/2 Screws Installed	
Material:Steel-0.0625"-G60 Galvanized	

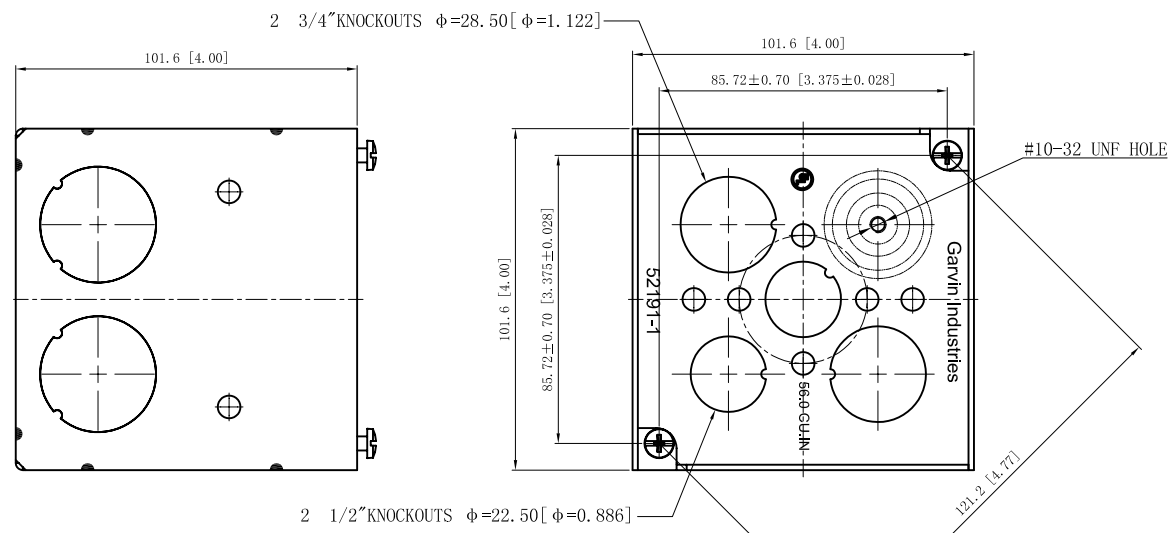
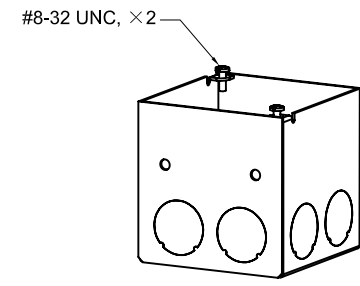
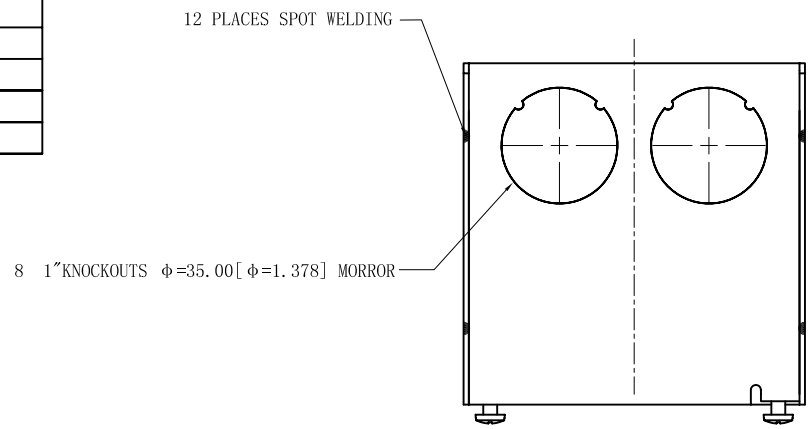

This data sheet is for reference only .GARVIN INDUSTRIES reserves the right to make changes to the design without prior notice.

DESCRIPTION
TRADE REFERENCE TERMS

STANDARD PACKING	GARVIN INDUSTRIES		
	TITLE 4" SQUARE BOXES 4" DEEP		
10 PCS	SIZE	DWG NO.	REV
	A4	52191-1	
DATA SHEET			